

## ISO732x-Q1 Robust EMC, Low Power, Dual-Channel Digital Isolators

### 1 Features

- Qualified for Automotive Applications
- AEC-Q100 Qualified With the Following Results:
  - Device Temperature Grade 1:  $-40^{\circ}\text{C}$  to  $+125^{\circ}\text{C}$  Ambient Operating Temperature Range
  - Device HBM Classification Level 3A
  - Device CDM Classification Level C6
- Signaling Rate: 25 Mbps
- Integrated Noise Filter on the Inputs
- Default Output *High* and *Low* Options
- Low Power Consumption: Typical  $I_{CC}$  per Channel at 1 Mbps:
  - ISO7320-Q1: 1.2 mA (5-V Supplies), 0.9 mA (3.3-V Supplies)
  - ISO7321-Q1: 1.7 mA (5-V Supplies), 1.2 mA (3.3-V Supplies)
- Low Propagation Delay: 33 ns Typical (5-V Supplies)
- 3.3-V and 5-V Level Translation
- 65-kV/ $\mu\text{s}$  Transient Immunity, Typical (5-V Supplies)
- Robust Electromagnetic Compatibility (EMC)
  - System-level ESD, EFT, and Surge Immunity
  - Low Emissions
- Isolation Barrier Life: > 25 Years
- Operates from 3.3-V and 5-V Supplies
- Narrow Body SOIC-8 Package
- Safety and Regulatory Approvals:
  - 4242- $V_{PK}$  Isolation per DIN V VDE V 0884-10 and DIN EN 61010-1
  - 3000- $V_{RMS}$  Isolation for 1 minute per UL 1577
  - CSA Component Acceptance Notice 5A, IEC 60950-1 and IEC 61010-1 Standards
  - Planned CQC Certification per GB4943.1-2011

### 2 Applications

- Opto-Coupler Replacement in:
  - Industrial FieldBus
    - ProfiBus
    - ModBus
    - DeviceNet™ Data Buses
  - Servo Control Interface
  - Motor Control

- Power Supplies
- Battery Packs

### 3 Description

The ISO732x-Q1 family of devices provides galvanic isolation up to 3000  $V_{RMS}$  for 1 minute per UL 1577 and 4242  $V_{PK}$  per VDE V 0884-10. These devices have two isolated channels comprised of logic input and output buffers separated by silicon dioxide ( $\text{SiO}_2$ ) insulation barriers.

The ISO7320-Q1 has both channels in the same direction while ISO7321-Q1 has the two channels in opposite direction. In case of input power or signal loss, the default output is *low* for orderable part numbers with suffix *F* and *high* for orderable part numbers without suffix *F*. See [Device Functional Modes](#) for more information. Used in conjunction with isolated power supplies, these devices prevent noise currents on a data bus or other circuits from entering the local ground and interfering with or damaging sensitive circuitry. The ISO732x-Q1 family of devices has integrated noise filters for harsh industrial environment where short noise pulses may be present at the device input pins. The ISO732x-Q1 family of devices has TTL input thresholds and operate from 3-V to 5.5-V supply levels.

Through innovative chip design and layout techniques, electromagnetic compatibility of the ISO732x-Q1 family of devices has been significantly enhanced to enable system-level ESD, EFT, Surge and Emissions compliance.

#### Device Information<sup>(1)</sup>

PART NUMBER	PACKAGE	BODY SIZE (NOM)
ISO7320-Q1	SOIC (8)	4.90 mm × 3.91 mm
ISO7321-Q1		

(1) For all available packages, see the orderable addendum at the end of the datasheet.

#### Simplified Schematic

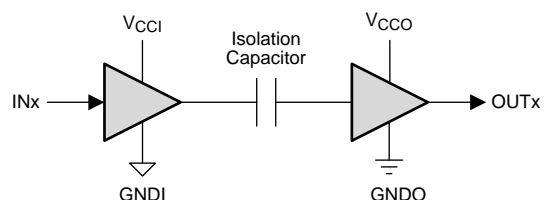

$V_{CCI}$  and  $GNDI$  are supply and ground connections respectively for the input channels.

$V_{CCO}$  and  $GNDO$  are supply and ground connections respectively for the output channels.



## Table of Contents

<b>1 Features</b> .....	<b>1</b>	8.1 Overview .....	11
<b>2 Applications</b> .....	<b>1</b>	8.2 Functional Block Diagram .....	11
<b>3 Description</b> .....	<b>1</b>	8.3 Feature Description .....	12
<b>4 Revision History</b> .....	<b>2</b>	8.4 Device Functional Modes .....	15
<b>5 Pin Configuration and Functions</b> .....	<b>3</b>	<b>9 Application and Implementation</b> .....	<b>16</b>
<b>6 Specifications</b> .....	<b>4</b>	9.1 Application Information .....	16
6.1 Absolute Maximum Ratings .....	4	9.2 Typical Application .....	16
6.2 ESD Ratings .....	4	<b>10 Power Supply Recommendations</b> .....	<b>18</b>
6.3 Recommended Operating Conditions .....	4	<b>11 Layout</b> .....	<b>18</b>
6.4 Thermal Information .....	4	11.1 Layout Guidelines .....	18
6.5 Electrical Characteristics—5-V Supply .....	5	11.2 Layout Example .....	19
6.6 Supply Current Characteristics—5-V Supply .....	5	<b>12 Device and Documentation Support</b> .....	<b>20</b>
6.7 Electrical Characteristics—3.3 V .....	6	12.1 Documentation Support .....	20
6.8 Supply Current Characteristics—3.3-V Supply .....	6	12.2 Related Links .....	20
6.9 Power Dissipation Characteristics .....	6	12.3 Community Resource .....	20
6.10 Switching Characteristics—5-V Supply .....	7	12.4 Trademarks .....	20
6.11 Switching Characteristics—3.3-V Supply .....	7	12.5 Electrostatic Discharge Caution .....	20
6.12 Typical Characteristics .....	8	12.6 Glossary .....	20
<b>7 Parameter Measurement Information</b> .....	<b>10</b>	<b>13 Mechanical, Packaging, and Orderable Information</b> .....	<b>20</b>
<b>8 Detailed Description</b> .....	<b>11</b>		

## 4 Revision History

NOTE: Page numbers for previous revisions may differ from page numbers in the current version.

DATE	REVISION	NOTES
November 2015	*	Initial release.

## 5 Pin Configuration and Functions



### Pin Functions

NAME	PIN		I/O	DESCRIPTION
	NO.			
	ISO7320-Q1	ISO7321-Q1		
INA	2	7	I	Input, channel A
INB	3	3	I	Input, channel B
GND1	4	4	—	Ground connection for $V_{CC1}$
GND2	5	5	—	Ground connection for $V_{CC2}$
OUTA	7	2	O	Output, channel A
OUTB	6	6	O	Output, channel B
$V_{CC1}$	1	1	—	Power supply, $V_{CC1}$
$V_{CC2}$	8	8	—	Power supply, $V_{CC2}$

## 6 Specifications

### 6.1 Absolute Maximum Ratings

over operating free-air temperature range (unless otherwise noted)<sup>(1)</sup>

			MIN	MAX	UNIT
V <sub>CC</sub>	Supply voltage <sup>(2)</sup>	V <sub>CC1</sub> , V <sub>CC2</sub>	-0.5	6	V
	Voltage <sup>(2)</sup>	INx, OUTx	-0.5	V <sub>CC</sub> + 0.5 <sup>(3)</sup>	V
I <sub>O</sub>	Output current			±15	mA
T <sub>J</sub>	Junction temperature			150	°C
T <sub>stg</sub>	Storage temperature		-65	150	°C

- (1) Stresses beyond those listed under *absolute maximum ratings* may cause permanent damage to the device. These are stress ratings only and functional operation of the device at these or any other conditions beyond those indicated under *recommended operating conditions* is not implied. Exposure to absolute-maximum-rated conditions for extended periods may affect device reliability.
- (2) All voltage values are with respect to network ground terminal and are peak voltage values.
- (3) Maximum voltage must not exceed 6 V.

### 6.2 ESD Ratings

			VALUE	UNIT
V <sub>(ESD)</sub>	Electrostatic discharge	Human-body model (HBM), per AEC Q100-002 <sup>(1)</sup>	±4000	V
		Charged-device model (CDM), per AEC Q100-011	±1500	

- (1) AEC Q100-002 indicates that HBM stressing shall be in accordance with the ANSI/ESDA/JEDEC JS-001 specification.

### 6.3 Recommended Operating Conditions

		MIN	NOM	MAX	UNIT
V <sub>CC1</sub> , V <sub>CC2</sub>	Supply voltage,	3		5.5	V
I <sub>OH</sub>	High-level output current	-4			mA
I <sub>OL</sub>	Low-level output current			4	mA
V <sub>IH</sub>	High-level input voltage	2		5.5	V
V <sub>IL</sub>	Low-level input voltage	0		0.8	V
t <sub>ui</sub>	Input pulse duration	40			ns
1 / t <sub>ui</sub>	Signaling rate	0		25	Mbps
T <sub>J</sub> <sup>(1)</sup>	Junction temperature			136	°C
T <sub>A</sub>	Ambient temperature	-40	25	125	°C

- (1) To maintain the recommended operating conditions for T<sub>J</sub>, see the [Thermal Information](#) table.

### 6.4 Thermal Information

THERMAL METRIC <sup>(1)</sup>	ISO732x-Q1		UNIT
	D (SOIC)		
	8 PINS		
R <sub>θJA</sub>	Junction-to-ambient thermal resistance	121	°C/W
R <sub>θJctop</sub>	Junction-to-case (top) thermal resistance	67.9	°C/W
R <sub>θJB</sub>	Junction-to-board thermal resistance	61.6	°C/W
ψ <sub>JT</sub>	Junction-to-top characterization parameter	21.5	°C/W
ψ <sub>JB</sub>	Junction-to-board characterization parameter	61.1	°C/W
R <sub>θJcbot</sub>	Junction-to-case (bottom) thermal resistance	N/A	°C/W

- (1) For more information about traditional and new thermal metrics, see the *Semiconductor and IC Package Thermal Metrics application report*, [SPRA953](#).

## 6.5 Electrical Characteristics—5-V Supply

 $V_{CC1}$  and  $V_{CC2}$  at 5 V  $\pm$  10% (over recommended operating conditions unless otherwise noted)

PARAMETER		TEST CONDITIONS	MIN	TYP	MAX	UNIT
$V_{OH}$	High-level output voltage	$I_{OH} = -4$ mA; see <a href="#">Figure 11</a>	$V_{CCO}^{(1)} - 0.5$	4.7		V
		$I_{OH} = -20$ $\mu$ A; see <a href="#">Figure 11</a>	$V_{CCO}^{(1)} - 0.1$	5		
$V_{OL}$	Low-level output voltage	$I_{OL} = 4$ mA; see <a href="#">Figure 11</a>		0.2	0.4	V
		$I_{OL} = 20$ $\mu$ A; see <a href="#">Figure 11</a>		0	0.1	
$V_{I(HYS)}$	Input threshold voltage hysteresis			460		mV
$I_{IH}$	High-level input current	$I_N = V_{CC}$			10	$\mu$ A
$I_{IL}$	Low-level input current	$I_N = 0$ V	-10			$\mu$ A
CMTI	Common-mode transient immunity	$V_I = V_{CC}$ or 0 V; see <a href="#">Figure 13</a> .	25	65		kV/ $\mu$ s

(1)  $V_{CCO}$  is supply voltage,  $V_{CC1}$  or  $V_{CC2}$ , for the output channel being measured.

## 6.6 Supply Current Characteristics—5-V Supply

All inputs switching with square wave clock signal for dynamic  $I_{CC}$  measurement.  $V_{CC1}$  and  $V_{CC2}$  at 5 V  $\pm$  10% (over recommended operating conditions unless otherwise noted)

PARAMETER	TEST CONDITIONS		SUPPLY CURRENT	MIN	TYP	MAX	UNIT
<b>ISO7320-Q1</b>							
Supply current for $V_{CC1}$ and $V_{CC2}$	DC to 1 Mbps	DC Input: $V_I = V_{CC}$ or 0 V, AC Input: $C_L = 15$ pF	$I_{CC1}$		0.4	0.9	mA
			$I_{CC2}$		2	3.2	
	10 Mbps	$C_L = 15$ pF	$I_{CC1}$		0.8	1.4	
			$I_{CC2}$		3.2	4.4	
	25 Mbps	$C_L = 15$ pF	$I_{CC1}$		1.4	2.3	
			$I_{CC2}$		4.9	6.8	
<b>ISO7321-Q1</b>							
Supply current for $V_{CC1}$ and $V_{CC2}$	DC to 1 Mbps	DC Input: $V_I = V_{CC}$ or 0 V, AC Input: $C_L = 15$ pF	$I_{CC1}$ , $I_{CC2}$		1.7	2.8	mA
	10 Mbps	$C_L = 15$ pF	$I_{CC1}$ , $I_{CC2}$		2.5	3.7	
	25 Mbps	$C_L = 15$ pF	$I_{CC1}$ , $I_{CC2}$		3.7	5.4	

## 6.7 Electrical Characteristics—3.3 V

$V_{CC1}$  and  $V_{CC2}$  at 3.3 V  $\pm$  10% (over recommended operating conditions unless otherwise noted)

PARAMETER	TEST CONDITIONS	MIN	TYP	MAX	UNIT
$V_{OH}$ High-level output voltage	$I_{OH} = -4$ mA; see Figure 11	$V_{CCO}^{(1)} - 0.5$	3		V
	$I_{OH} = -20$ $\mu$ A; see Figure 11	$V_{CCO}^{(1)} - 0.1$	3.3		
$V_{OL}$ Low-level output voltage	$I_{OL} = 4$ mA; see Figure 11		0.2	0.4	V
	$I_{OL} = 20$ $\mu$ A; see Figure 11		0	0.1	
$V_{I(HYS)}$ Input threshold voltage hysteresis			450		mV
$I_{IH}$ High-level input current	$I_N = V_{CC}$			10	$\mu$ A
$I_{IL}$ Low-level input current	$I_N = 0$ V	-10			$\mu$ A
CMTI Common-mode transient immunity	$V_I = V_{CC}$ or 0 V; see Figure 13	25	50		kV/ $\mu$ s

(1)  $V_{CCO}$  is supply voltage,  $V_{CC1}$  or  $V_{CC2}$ , for the output channel being measured.

## 6.8 Supply Current Characteristics—3.3-V Supply

All inputs switching with square wave clock signal for dynamic  $I_{CC}$  measurement.  $V_{CC1}$  and  $V_{CC2}$  at 3.3 V  $\pm$  10% (over recommended operating conditions unless otherwise noted)

PARAMETER	TEST CONDITIONS	SUPPLY CURRENT	MIN	TYP	MAX	UNIT
<b>ISO7320-Q1</b>						
Supply current for $V_{CC1}$ and $V_{CC2}$	DC to 1 Mbps	DC Input: $V_I = V_{CC}$ or 0 V, AC Input: $C_L = 15$ pF	$I_{CC1}$	0.2	0.5	mA
			$I_{CC2}$	1.5	2.5	
	10 Mbps	$C_L = 15$ pF	$I_{CC1}$	0.5	0.8	
			$I_{CC2}$	2.2	3.2	
	25 Mbps	$C_L = 15$ pF	$I_{CC1}$	0.9	1.4	
			$I_{CC2}$	3.3	4.7	
<b>ISO7321-Q1</b>						
Supply current for $V_{CC1}$ and $V_{CC2}$	DC to 1 Mbps	DC Input: $V_I = V_{CC}$ or 0 V, AC Input: $C_L = 15$ pF	$I_{CC1}, I_{CC2}$	1.2	2	mA
	10 Mbps	$C_L = 15$ pF	$I_{CC1}, I_{CC2}$	1.7	2.5	
	25 Mbps	$C_L = 15$ pF	$I_{CC1}, I_{CC2}$	2.5	3.6	

## 6.9 Power Dissipation Characteristics

$V_{CC1} = V_{CC2} = 5.5$  V,  $T_J = 150^\circ$ C,  $C_L = 15$  pF, input a 12.5 MHz 50% duty-cycle square wave (unless otherwise noted)

PARAMETER	TEST CONDITIONS	MIN	TYP	MAX	UNIT
$P_D$ Maximum power dissipation by ISO7320-Q1				56	mW
$P_{D1}$ Maximum power dissipation by side-1 of ISO7320-Q1				15	mW
$P_{D2}$ Maximum power dissipation by side-2 of ISO7320-Q1				41	mW
$P_D$ Maximum power dissipation by ISO7321-Q1				67	mW
$P_{D1}$ Maximum power dissipation by side-1 of ISO7321-Q1				33.5	mW
$P_{D2}$ Maximum power dissipation by side-2 of ISO7321-Q1				33.5	mW

## 6.10 Switching Characteristics—5-V Supply

$V_{CC1}$  and  $V_{CC2}$  at 5 V  $\pm$  10% (over recommended operating conditions unless otherwise noted)

PARAMETER		TEST CONDITIONS	MIN	TYP	MAX	UNIT
$t_{PLH}$ , $t_{PHL}$	Propagation delay time	See <a href="#">Figure 11</a>	20	33	57	ns
PWD <sup>(1)</sup>	Pulse width distortion $ t_{PHL} - t_{PLH} $	See <a href="#">Figure 11</a>			4	ns
$t_{sk(o)}$ <sup>(2)</sup>	Channel-to-channel output skew time	ISO7320-Q1			2	ns
		ISO7321-Q1			17	
$t_{sk(pp)}$ <sup>(3)</sup>	Part-to-part skew time				23	ns
$t_r$	Output signal rise time	See <a href="#">Figure 11</a>		2.4		ns
$t_f$	Output signal fall time	See <a href="#">Figure 11</a>		2.1		ns
$t_{fs}$	Fail-safe output delay time from input power loss	See <a href="#">Figure 12</a>		7.5		$\mu$ s

- (1) Also known as pulse skew.
- (2)  $t_{sk(o)}$  is the skew between outputs of a single device with all driving inputs connected together and the outputs switching in the same direction while driving identical loads.
- (3)  $t_{sk(pp)}$  is the magnitude of the difference in propagation delay times between any terminals of different devices switching in the same direction while operating at identical supply voltages, temperature, input signals and loads.

## 6.11 Switching Characteristics—3.3-V Supply

$V_{CC1}$  and  $V_{CC2}$  at 3.3 V  $\pm$  10% (over recommended operating conditions unless otherwise noted)

PARAMETER		TEST CONDITIONS	MIN	TYP	MAX	UNIT
$t_{PLH}$ , $t_{PHL}$	Propagation delay time	See <a href="#">Figure 11</a>	22	37	66	ns
PWD <sup>(1)</sup>	Pulse width distortion $ t_{PHL} - t_{PLH} $	See <a href="#">Figure 11</a>			3	ns
$t_{sk(o)}$ <sup>(2)</sup>	Channel-to-channel output skew time	ISO7320-Q1			3	ns
		ISO7321-Q1			16	
$t_{sk(pp)}$ <sup>(3)</sup>	Part-to-part skew time				28	ns
$t_r$	Output signal rise time	See <a href="#">Figure 11</a>		3.1		ns
$t_f$	Output signal fall time	See <a href="#">Figure 11</a>		2.6		ns
$t_{fs}$	Fail-safe output delay time from input power loss	See <a href="#">Figure 12</a>		7.4		$\mu$ s

- (1) Also known as pulse skew.
- (2)  $t_{sk(o)}$  is the skew between outputs of a single device with all driving inputs connected together and the outputs switching in the same direction while driving identical loads.
- (3)  $t_{sk(pp)}$  is the magnitude of the difference in propagation delay times between any terminals of different devices switching in the same direction while operating at identical supply voltages, temperature, input signals and loads.

## 6.12 Typical Characteristics

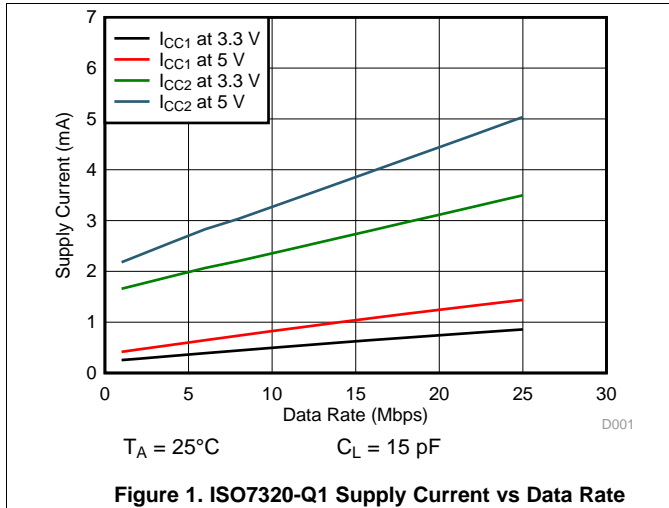

Figure 1. ISO7320-Q1 Supply Current vs Data Rate

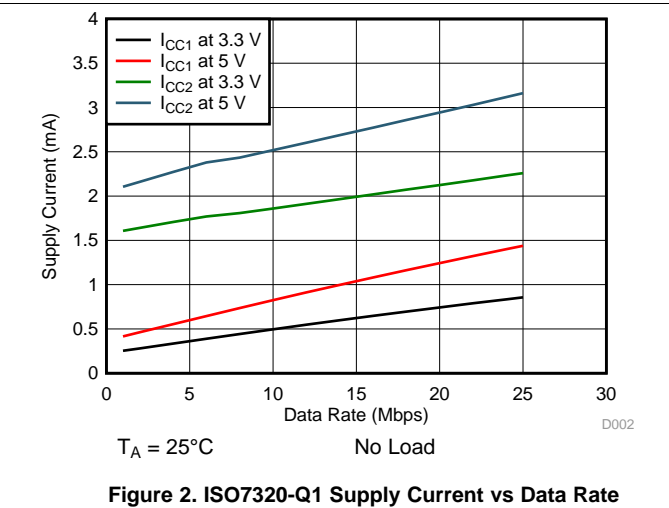

Figure 2. ISO7320-Q1 Supply Current vs Data Rate

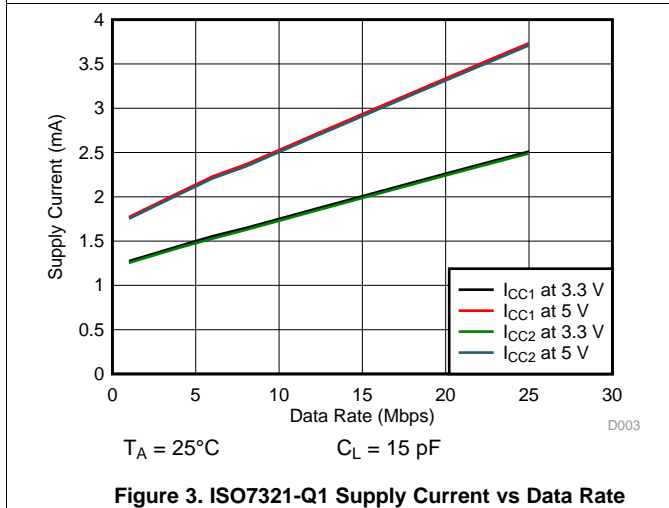

Figure 3. ISO7321-Q1 Supply Current vs Data Rate

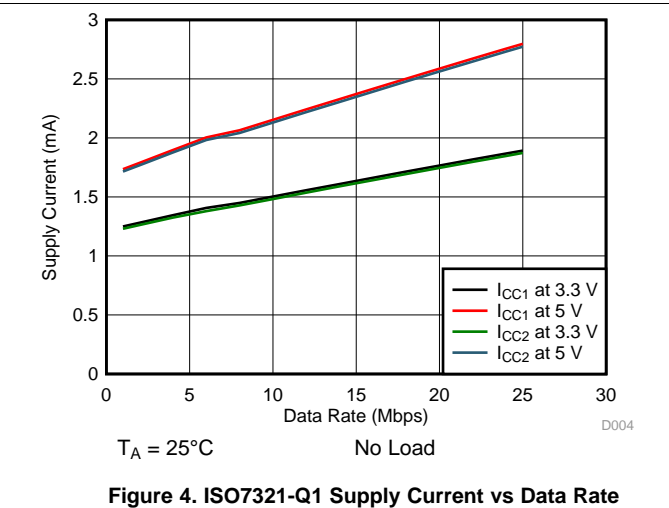

Figure 4. ISO7321-Q1 Supply Current vs Data Rate

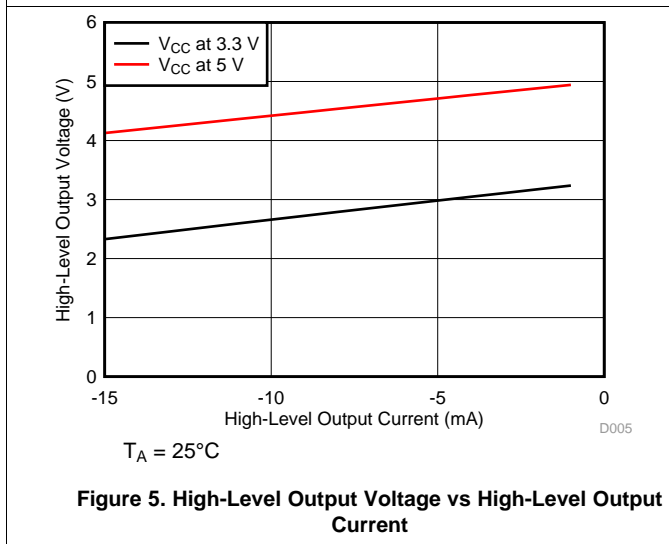

Figure 5. High-Level Output Voltage vs High-Level Output Current

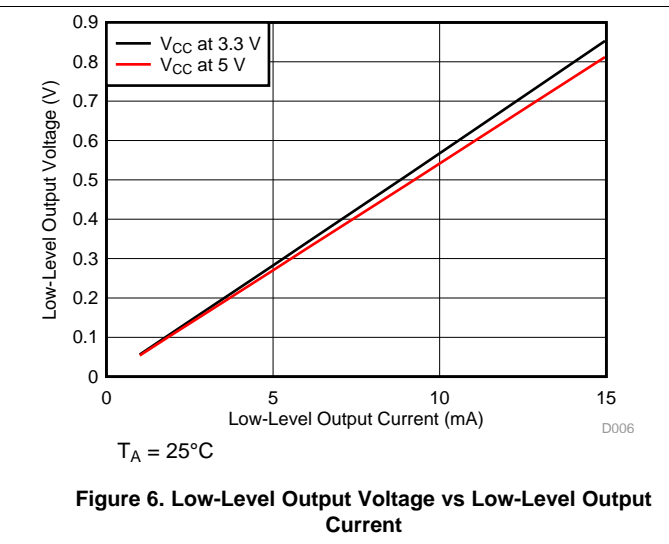

Figure 6. Low-Level Output Voltage vs Low-Level Output Current

Typical Characteristics (continued)

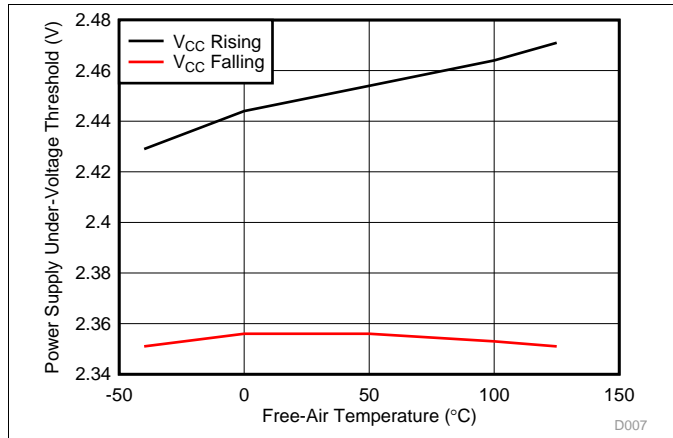

Figure 7. Power Supply Under Voltage Threshold vs Free-Air Temperature

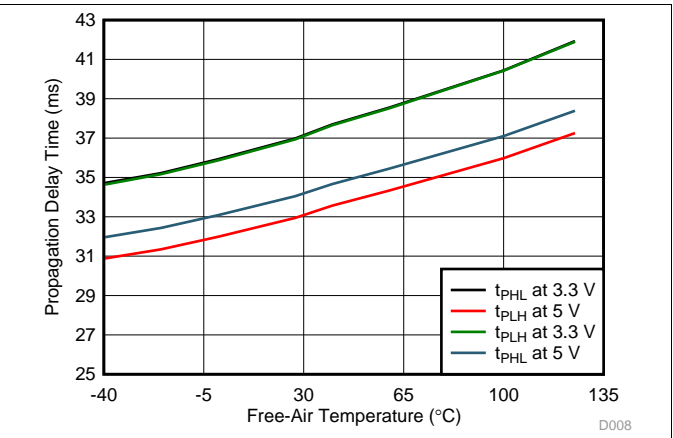

Figure 8. Propagation Delay Time vs Free-Air Temperature

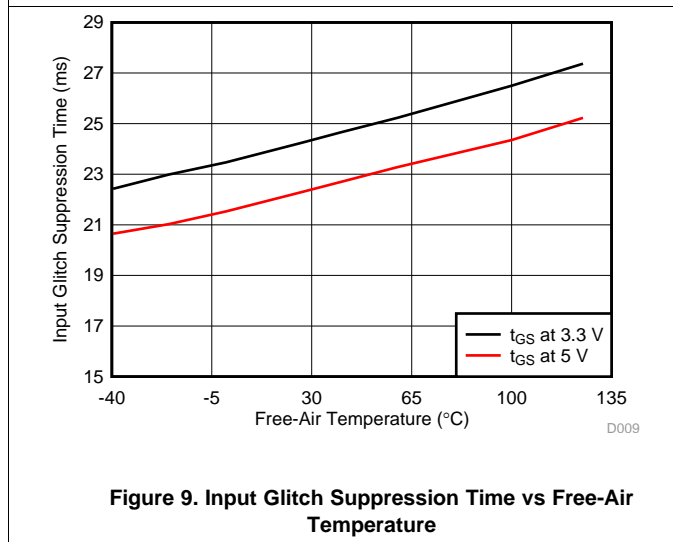

Figure 9. Input Glitch Suppression Time vs Free-Air Temperature

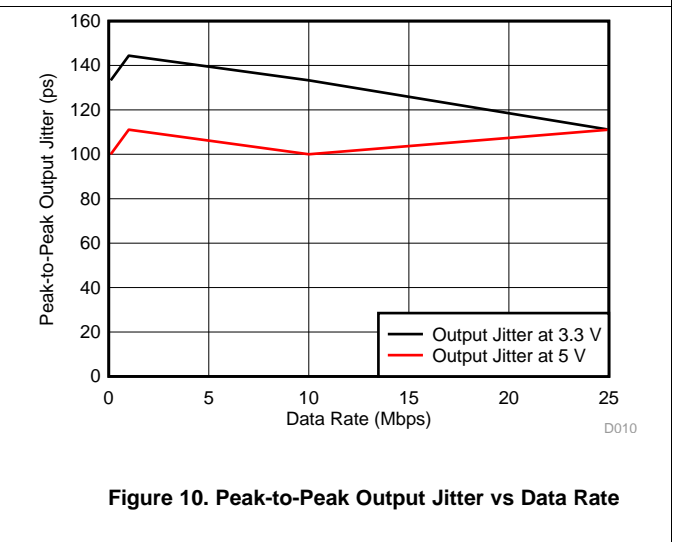
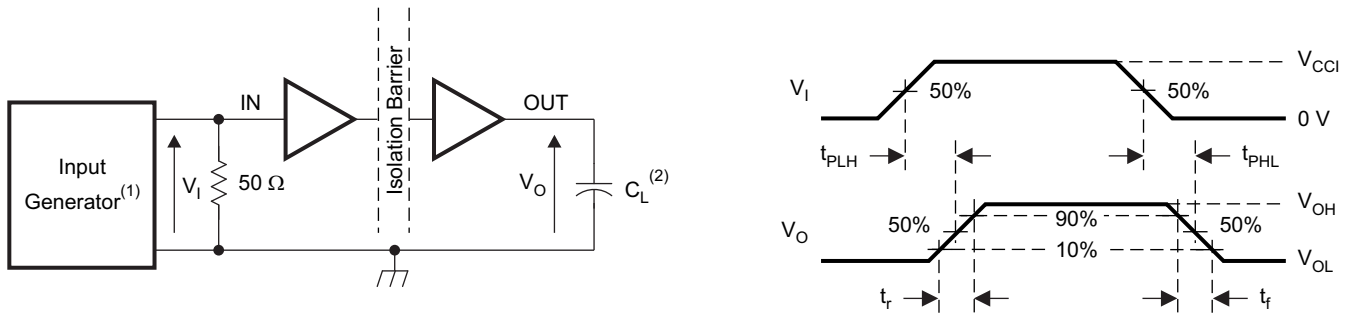

Figure 10. Peak-to-Peak Output Jitter vs Data Rate

## 7 Parameter Measurement Information



- (1) The input pulse is supplied by a generator having the following characteristics: PRR  $\leq$  50 kHz, 50% duty cycle,  $t_r \leq$  3 ns,  $t_f \leq$  3 ns,  $Z_o = 50 \Omega$ . At the input, a 50- $\Omega$  resistor is required to terminate the Input Generator signal. It is not needed in actual application.
- (2)  $C_L = 15$  pF and includes instrumentation and fixture capacitance within  $\pm 20\%$ .

**Figure 11. Switching Characteristic Test Circuit and Voltage Waveforms**

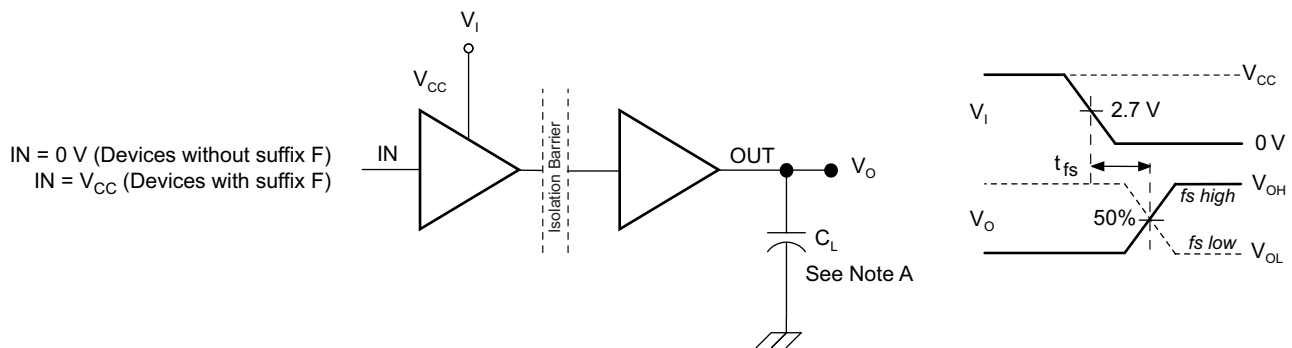

- A.  $C_L = 15$  pF and includes instrumentation and fixture capacitance within  $\pm 20\%$ .

**Figure 12. Fail-Safe Output Delay-Time Test Circuit and Voltage Waveforms**

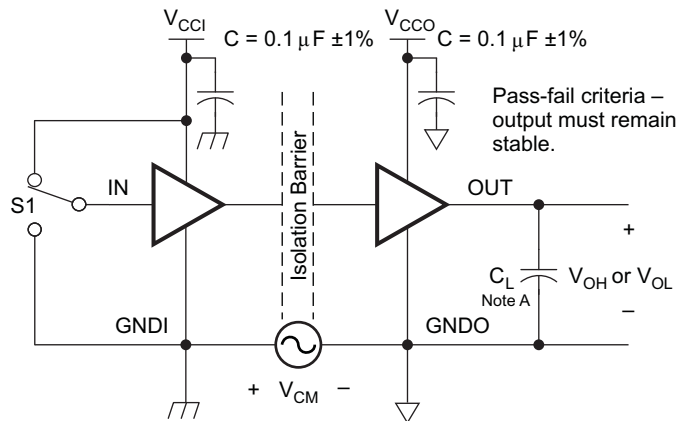

- (1)  $C_L = 15$  pF and includes instrumentation and fixture capacitance within  $\pm 20\%$ .

**Figure 13. Common-Mode Transient Immunity Test Circuit**

## 8 Detailed Description

### 8.1 Overview

The isolator in Figure 14 is based on a capacitive isolation barrier technique. The I/O channel of the device consists of two internal data channels, a high-frequency (HF) channel with a bandwidth from 100 kbps up to 25 Mbps, and a low-frequency (LF) channel covering the range from 100 kbps down to DC.

In principle, a single-ended input signal entering the HF channel is split into a differential signal via the inverter gate at the input. The following capacitor-resistor networks differentiate the signal into transient pulses, which then are converted into CMOS levels by a comparator. The transient pulses at the input of the comparator can be either above or below the common mode voltage  $V_{REF}$  depending on whether the input bit transitions from 0 to 1 or 1 to 0. The comparator threshold is adjusted based on the expected bit transition. A decision logic (DCL) at the output of the HF channel comparator measures the durations between signal transients. If the duration between two consecutive transients exceeds a certain time limit, (as in the case of a low-frequency signal), the DCL forces the output-multiplexer to switch from the high-frequency to the low-frequency channel.

### 8.2 Functional Block Diagram

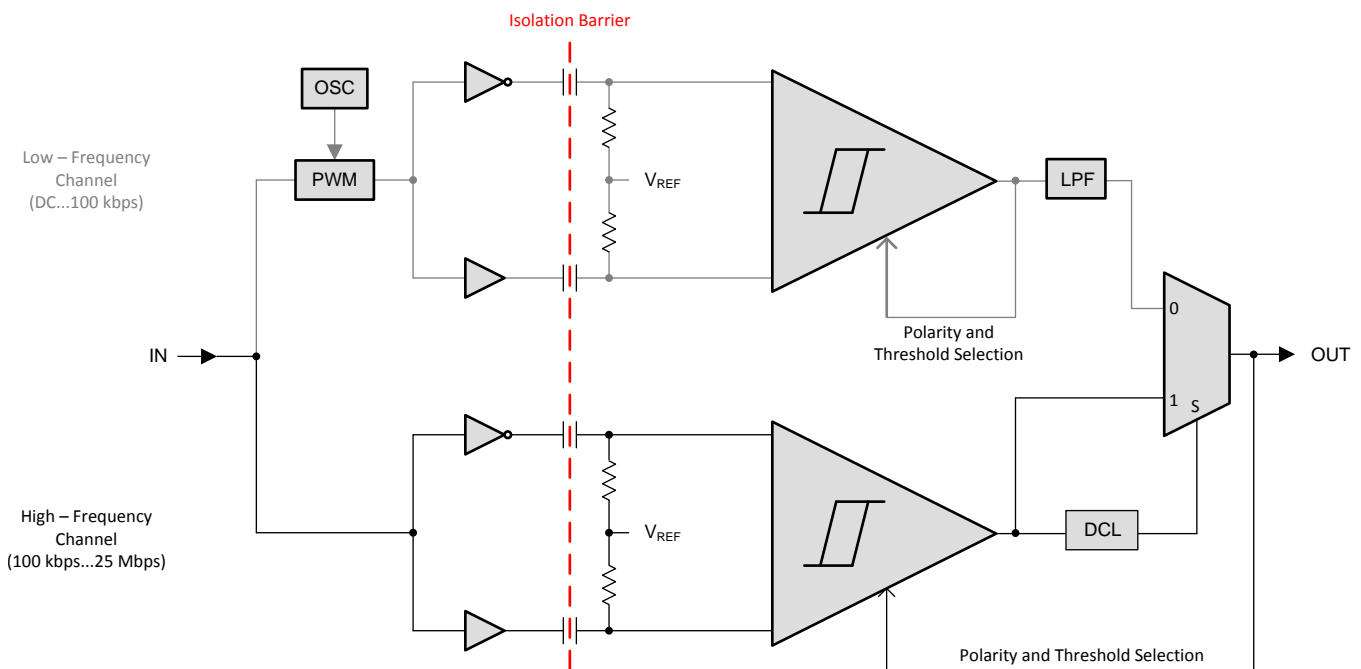

Figure 14. Conceptual Block Diagram of a Digital Capacitive Isolator

Because low-frequency input signals require the internal capacitors to assume prohibitively large values, these signals are pulse-width modulated (PWM) with the carrier frequency of an internal oscillator, thus creating a sufficiently high frequency, capable of passing the capacitive barrier. As the input is modulated, a low-pass filter (LPF) is required to remove the high-frequency carrier from the actual data before passing it on to the output multiplexer.

### 8.3 Feature Description

ORDERABLE DEVICE	CHANNEL DIRECTION	RATED ISOLATION	MAX DATA RATE	DEFAULT OUTPUT
ISO7320CQDQ1 and ISO7320CQDRQ1	Same	3000 V <sub>RMS</sub> / 4242 V <sub>PK</sub> <sup>(1)</sup>	25 Mbps	High
ISO7320FCQDQ1 and ISO7320FCQDRQ1				Low
ISO7321CQDQ1 and ISO7321CQDRQ1	Opposite			High
ISO7321FCQDQ1 and ISO7321FCQDRQ1				Low

(1) See the [Regulatory Information](#) section for detailed Isolation Ratings

#### 8.3.1 High Voltage Feature Description

##### 8.3.1.1 Insulation and Safety-Related Specifications for D-8 Package

over recommended operating conditions (unless otherwise noted)

PARAMETER		TEST CONDITIONS	MIN	TYP	MAX	UNIT
L(I01)	Minimum air gap (clearance)	Shortest terminal-to-terminal distance through air	4			mm
L(I02)	Minimum external tracking (creepage)	Shortest terminal-to-terminal distance across the package surface	4			mm
CTI	Tracking resistance (comparative tracking index)	DIN EN 60112 (VDE 0303-11); IEC 60112	400			V
DTI	Minimum internal gap (internal clearance)	Distance through insulation	13			µm
R <sub>IO</sub>	Isolation resistance, input to output <sup>(1)</sup>	V <sub>IO</sub> = 500 V, T <sub>A</sub> = 25°C	10 <sup>12</sup>			Ω
		V <sub>IO</sub> = 500 V, 100°C ≤ T <sub>A</sub> ≤ 125°C	10 <sup>11</sup>			Ω
C <sub>IO</sub>	Isolation capacitance, input to output <sup>(1)</sup>	V <sub>IO</sub> = 0.4 sin(2πft), f = 1 MHz		1.5		pF
C <sub>I</sub>	Input capacitance <sup>(2)</sup>	V <sub>I</sub> = V <sub>CC</sub> / 2 + 0.4 sin(2πft), f = 1 MHz, V <sub>CC</sub> = 5 V		1.8		pF

(1) All pins on each side of the barrier tied together creating a two-terminal device.

(2) Measured from input pin to ground.

#### NOTE

Creepage and clearance requirements should be applied according to the specific equipment isolation standards of an application. Care should be taken to maintain the creepage and clearance distance of a board design to ensure that the mounting pads of the isolator on the printed-circuit board do not reduce this distance.

Creepage and clearance on a printed-circuit board become equal in certain cases. Techniques such as inserting grooves, ribs, or both on a printed circuit board are used to help increase these specifications.

### 8.3.1.2 Insulation Characteristics

over recommended operating conditions (unless otherwise noted)

PARAMETER <sup>(1)</sup>		TEST CONDITIONS	SPECIFICATION	UNIT
V <sub>IOWM</sub>	Maximum isolation working voltage		400	V <sub>RMS</sub>
V <sub>IORM</sub>	Maximum repetitive peak voltage per DIN V VDE V 0884-10		566	V <sub>PK</sub>
V <sub>PR</sub>	Input-to-output test voltage per DIN V VDE V 0884-10	After Input/Output safety test subgroup 2/3, V <sub>PR</sub> = V <sub>IORM</sub> × 1.2, t = 10 s, Partial discharge < 5 pC	680	V <sub>PK</sub>
		Method a, After environmental tests subgroup 1, V <sub>PR</sub> = V <sub>IORM</sub> × 1.6, t = 10 s, Partial Discharge < 5 pC	906	
		Method b1, V <sub>PR</sub> = V <sub>IORM</sub> × 1.875, t = 1 s (100% Production test) Partial discharge < 5 pC	1062	
V <sub>IOTM</sub>	Maximum transient overvoltage per DIN V VDE V 0884-10	V <sub>TEST</sub> = V <sub>IOTM</sub> t = 60 sec (qualification) t = 1 sec (100% production)	4242	V <sub>PK</sub>
V <sub>IOSM</sub>	Maximum surge isolation voltage per DIN V VDE V 0884-10	Test method per IEC 60065, 1.2/50 μs waveform, V <sub>TEST</sub> = 1.3 × V <sub>IOSM</sub> = 7800 V <sub>PK</sub> (qualification)	6000	V <sub>PK</sub>
V <sub>ISO</sub>	Withstand isolation voltage per UL 1577	V <sub>TEST</sub> = V <sub>ISO</sub> = 3000 V <sub>RMS</sub> , t = 60 sec (qualification); V <sub>TEST</sub> = 1.2 × V <sub>ISO</sub> = 3600 V <sub>RMS</sub> , t = 1 sec (100% production)	3000	V <sub>RMS</sub>
R <sub>S</sub>	Insulation resistance	V <sub>IO</sub> = 500 V at T <sub>S</sub>	>10 <sup>9</sup>	Ω
	Pollution degree		2	

(1) Climatic Classification 40/125/21

**Table 1. IEC 60664-1 Ratings Table**

PARAMETER	TEST CONDITIONS	SPECIFICATION
Basic isolation group	Material group	II
Installation classification	Rated mains voltage ≤ 150 V <sub>RMS</sub>	I–IV
	Rated mains voltage ≤ 300 V <sub>RMS</sub>	I–III

### 8.3.1.3 Regulatory Information

VDE	CSA	UL	CQC
Certified according to DIN V VDE V 0884-10 (VDE V 0884-10):2006-12	Approved under CSA Component Acceptance Notice 5A, IEC 60950-1, and IEC 61010-1	Recognized under UL 1577 Component Recognition Program	Plan to certify according to GB4943.1-2011
Basic Insulation Maximum Transient Overvoltage, 4242 V <sub>PK</sub> Maximum Surge Isolation Voltage, 6000 V <sub>PK</sub> Maximum Repetitive Peak Voltage, 566 V <sub>PK</sub>	400 V <sub>RMS</sub> Basic Insulation and 200 V <sub>RMS</sub> Reinforced Insulation working voltage per CSA 60950-1-07+A1+A2 and IEC 60950-1 2nd Ed.+A1+A2; 300 V <sub>RMS</sub> Basic Insulation working voltage per CSA 61010-1-12 and IEC 61010-1 3rd Ed.	Single protection, 3000 V <sub>RMS</sub> <sup>(1)</sup>	Basic Insulation, Altitude ≤ 5000 m, Tropical Climate, 250 V <sub>RMS</sub> maximum working voltage
Certificate number: 40016131	Master contract number: 220991	File number: E181974	Certification Planned

(1) Production tested ≥ 3600 V<sub>RMS</sub> for 1 second in accordance with UL 1577.

### 8.3.1.4 Safety Limiting Values

Safety limiting intends to minimize potential damage to the isolation barrier upon failure of input or output circuitry. A failure of the I/O can allow low resistance to ground or the supply and, without current limiting, dissipate sufficient power to overheat the die and damage the isolation barrier, potentially leading to secondary system failures.

PARAMETER	TEST CONDITIONS	MIN	TYP	MAX	UNIT
I <sub>S</sub>	R <sub>θJA</sub> = 121 °C/W, V <sub>I</sub> = 5.5 V, T <sub>J</sub> = 150°C, T <sub>A</sub> = 25°C			188	mA
	R <sub>θJA</sub> = 121 °C/W, V <sub>I</sub> = 3.6 V, T <sub>J</sub> = 150°C, T <sub>A</sub> = 25°C			287	
T <sub>S</sub>				150	°C

The safety-limiting constraint is the absolute-maximum junction temperature specified in the [Absolute Maximum Ratings](#) table. The power dissipation and junction-to-air thermal impedance of the device installed in the application hardware determines the junction temperature. The assumed junction-to-air thermal resistance in the [Thermal Information](#) table is that of a device installed on a High-K Test Board for Leaded Surface-Mount Packages. The power is the recommended maximum input voltage times the current. The junction temperature is then the ambient temperature plus the power times the junction-to-air thermal resistance.

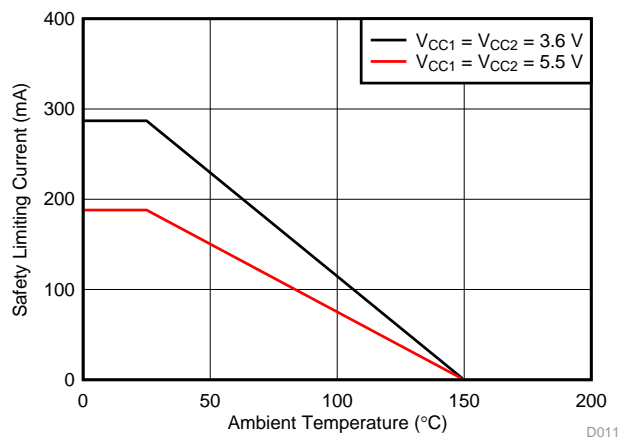

Figure 15. Thermal Derating Curve per VDE

### 8.4 Device Functional Modes

Table 2 lists the functional modes for the ISO732x-Q1 family of devices.

Table 2. Function Table<sup>(1)</sup>

V <sub>CCI</sub>	V <sub>CCO</sub>	INA, INB	OUTA, OUTB	
			ISO732xCQDQ1 AND ISO732xCQDRQ1	ISO732xFCQDQ1 AND ISO732xFCQDRQ1
PU	PU	H	H	H
		L	L	L
		Open	H <sup>(2)</sup>	L <sup>(3)</sup>
PD	PU	X	H <sup>(2)</sup>	L <sup>(3)</sup>
X	PD	X	Undetermined	Undetermined

- (1) V<sub>CCI</sub> = Input-side V<sub>CC</sub>; V<sub>CCO</sub> = Output-side V<sub>CC</sub>; PU = Powered up (V<sub>CC</sub> ≥ 3 V); PD = Powered down (V<sub>CC</sub> ≤ 2.1 V); X = Irrelevant; H = High level; L = Low level; Open = Not connected
- (2) In fail-safe condition, output defaults to high level
- (3) In fail-safe condition, output defaults to low level

#### 8.4.1 Device I/O Schematics

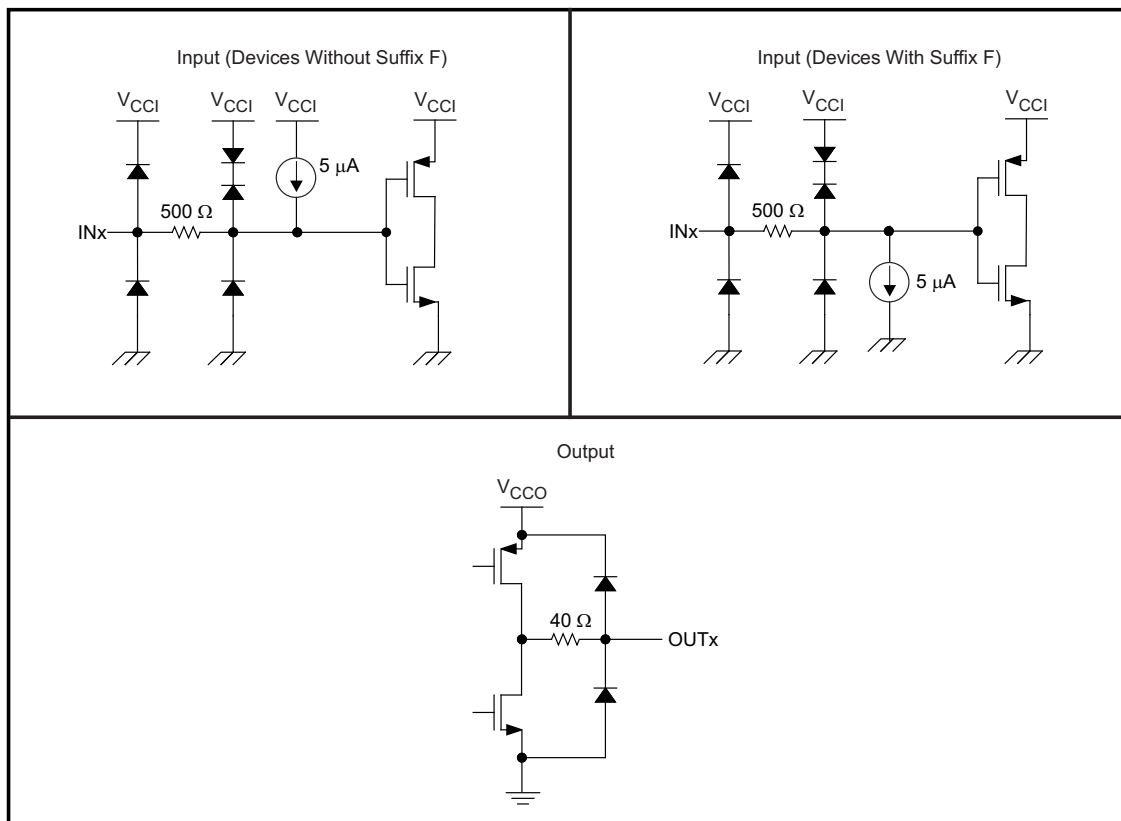

Figure 16. Device I/O Schematics

## 9 Application and Implementation

### NOTE

Information in the following applications sections is not part of the TI component specification, and TI does not warrant its accuracy or completeness. TI's customers are responsible for determining suitability of components for their purposes. Customers should validate and test their design implementation to confirm system functionality.

### 9.1 Application Information

The ISO732x-Q1 family of devices uses single-ended TTL-logic switching technology. The supply voltage range is from 3 V to 5.5 V for both supplies,  $V_{CC1}$  and  $V_{CC2}$ . When designing with digital isolators, keep in mind that because of the single-ended design structure, digital isolators do not conform to any specific interface standard and are only intended for isolating single-ended CMOS or TTL digital signal lines. The isolator is typically placed between the data controller (essentially,  $\mu\text{C}$  or UART), and a data converter or a line transceiver, regardless of the interface type or standard.

### 9.2 Typical Application

The ISO7321-Q1 device can be used with Texas Instruments' Piccolo™ microcontroller, CAN transceiver, transformer driver, and voltage regulator to create an isolated CAN interface.

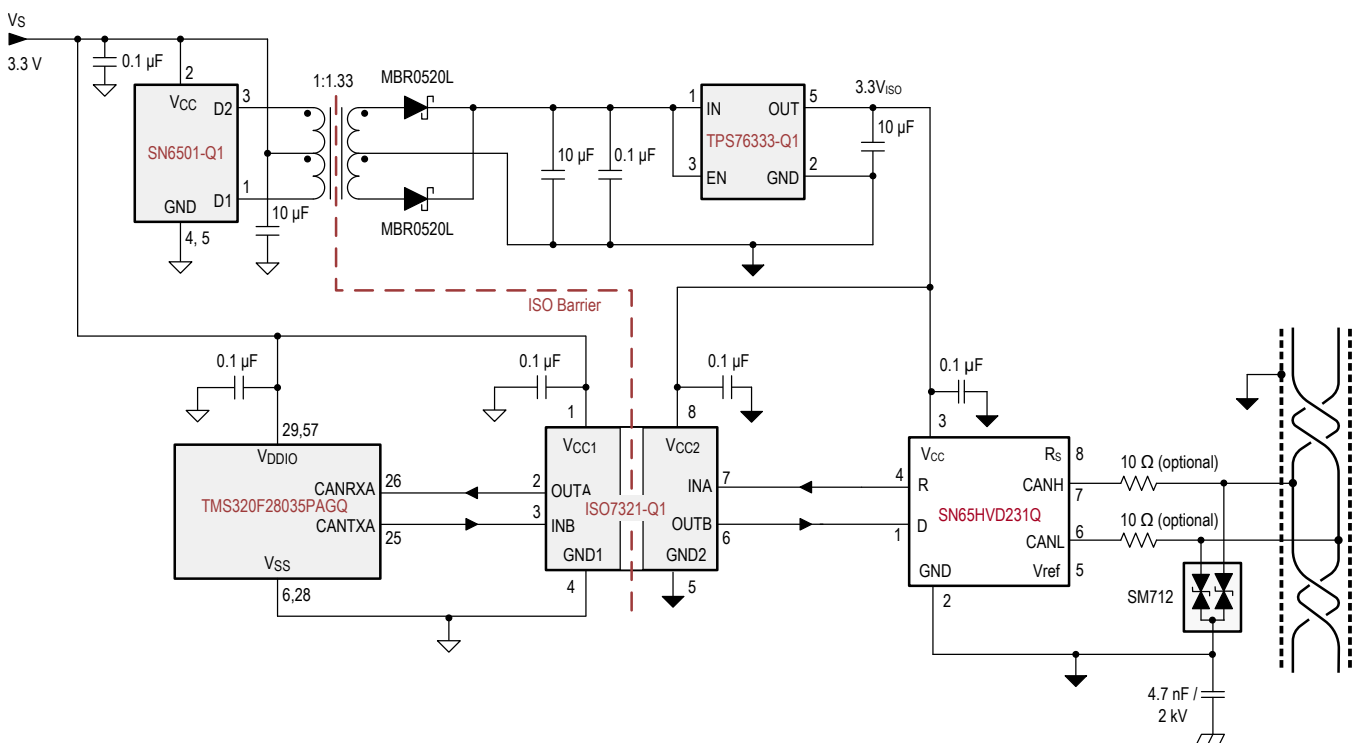

Multiple pins and discrete components omitted for clarity purpose.

**Figure 17. Isolated CAN Interface**

## Typical Application (continued)

### 9.2.1 Design Requirements

#### 9.2.1.1 Typical Supply Current Equations

For the equations in this section, the following is true:

- $I_{CC1}$  and  $I_{CC2}$  are typical supply currents measured in mA
- $f$  is the data rate measured in Mbps
- $C_L$  is the capacitive load measured in pF

##### 9.2.1.1.1 ISO7320-Q1

At  $V_{CC1} = V_{CC2} = 5\text{ V}$

$$I_{CC1} = 0.3838 + (0.0431 \times f) \quad (1)$$

$$I_{CC2} = 2.74567 + (0.08433 \times f) + (0.01 \times f \times C_L) \quad (2)$$

At  $V_{CC1} = V_{CC2} = 3.3\text{ V}$

$$I_{CC1} = 0.2394 + (0.02355 \times f) \quad (3)$$

$$I_{CC2} = 2.10681 + (0.04374 \times f) + (0.007045 \times f \times C_L) \quad (4)$$

##### 9.2.1.1.2 ISO7321-Q1

At  $V_{CC1} = V_{CC2} = 5\text{ V}$

$$I_{CC1} \text{ and } I_{CC2} = 1.5877 + (0.066 \times f) + (0.00123 \times f \times C_L) \quad (5)$$

At  $V_{CC1} = V_{CC2} = 3.3\text{ V}$

$$I_{CC1} \text{ and } I_{CC2} = 1.187572 + (0.019399 \times f) + (0.0019029 \times f \times C_L) \quad (6)$$

### 9.2.2 Detailed Design Procedure

#### 9.2.2.1 Electromagnetic Compatibility (EMC) Considerations

Many applications in harsh industrial environment are sensitive to disturbances such as electrostatic discharge (ESD), electrical fast transient (EFT), surge and electromagnetic emissions. These electromagnetic disturbances are regulated by international standards such as IEC 61000-4-x and CISPR 22. Although system-level performance and reliability depends, to a large extent, on the application board design and layout, the ISO732x-Q1 family of devices incorporates many chip-level design improvements for overall system robustness. Some of these improvements include:

- Robust ESD protection cells for input and output signal pins and inter-chip bond pads.
- Low-resistance connectivity of ESD cells to supply and ground pins.
- Enhanced performance of high voltage isolation capacitor for better tolerance of ESD, EFT and surge events.
- Bigger on-chip decoupling capacitors to bypass undesirable high energy signals through a low impedance path.
- PMOS and NMOS devices isolated from each other by using guard rings to avoid triggering of parasitic SCRs.
- Reduced common mode currents across the isolation barrier by ensuring purely differential internal operation.

## Typical Application (continued)

### 9.2.3 Application Curves

The following typical eye diagrams of the ISO732x-Q1 family of devices indicate low jitter and wide open eye at the maximum data rate of 25 Mbps.

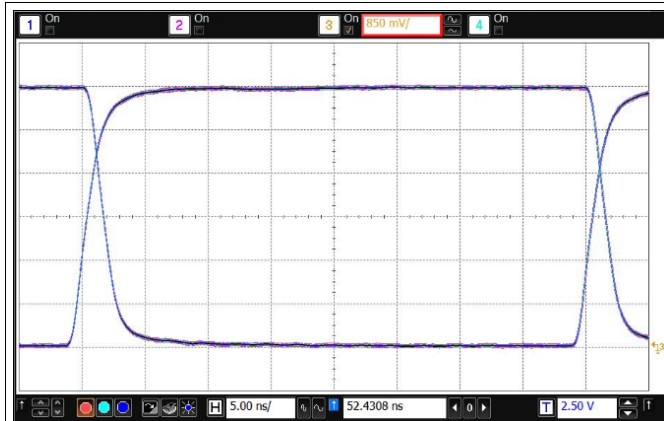

Figure 18. Eye Diagram at 25 Mbps, 5 V and 25°C

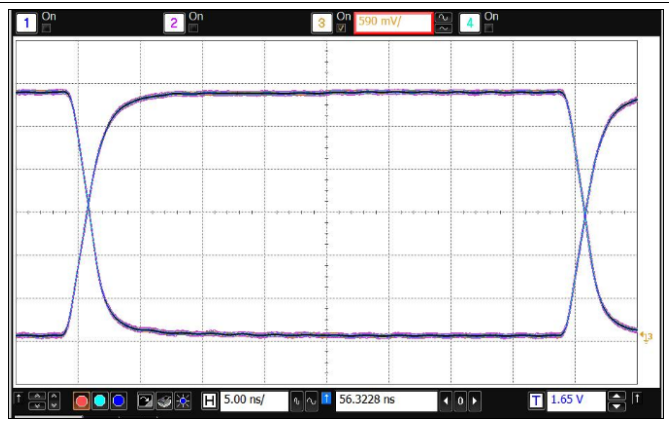

Figure 19. Eye Diagram at 25 Mbps, 3.3 V and 25°C

## 10 Power Supply Recommendations

To help ensure reliable operation at data rates and supply voltages, a 0.1- $\mu$ F bypass capacitor is recommended at the input and output supply pins ( $V_{CC1}$  and  $V_{CC2}$ ). The capacitors should be placed as close to the supply pins as possible. If only a single primary-side power supply is available in an application, isolated power can be generated for the secondary-side with the help of a transformer driver such as Texas Instruments' [SN6501-Q1](#). For such applications, detailed power supply design and transformer selection recommendations are available in the SN6501-Q1 datasheet ([SLLSEF3](#)).

## 11 Layout

### 11.1 Layout Guidelines

A minimum of four layers is required to accomplish a low EMI PCB design (see [Figure 20](#)). Layer stacking should be in the following order (top-to-bottom): high-speed signal layer, ground plane, power plane and low-frequency signal layer.

- Routing the high-speed traces on the top layer avoids the use of vias (and the introduction of their inductances) and allows for clean interconnects between the isolator and the transmitter and receiver circuits of the data link.
- Placing a solid ground plane next to the high-speed signal layer establishes controlled impedance for transmission line interconnects and provides an excellent low-inductance path for the return current flow.
- Placing the power plane next to the ground plane creates additional high-frequency bypass capacitance of approximately 100 pF/in<sup>2</sup>.
- Routing the slower speed control signals on the bottom layer allows for greater flexibility as these signal links usually have margin to tolerate discontinuities such as vias.

If an additional supply voltage plane or signal layer is needed, add a second power or ground plane system to the stack to keep it symmetrical. This makes the stack mechanically stable and prevents it from warping. Also the power and ground plane of each power system can be placed closer together, thus increasing the high-frequency bypass capacitance significantly.

For detailed layout recommendations, see the application note, *Digital Isolator Design Guide*, [SLLA284](#).

## Layout Guidelines (continued)

### 11.1.1 PCB Material

For digital circuit boards operating below 150 Mbps, (or rise and fall times higher than 1 ns), and trace lengths of up to 10 inches, use standard FR-4 UL94V-0 printed circuit board. This type of PCB is preferred over cheaper alternatives because of lower dielectric losses at high frequencies, less moisture absorption, greater strength and stiffness, and self-extinguishing flammability-characteristics.

### 11.2 Layout Example

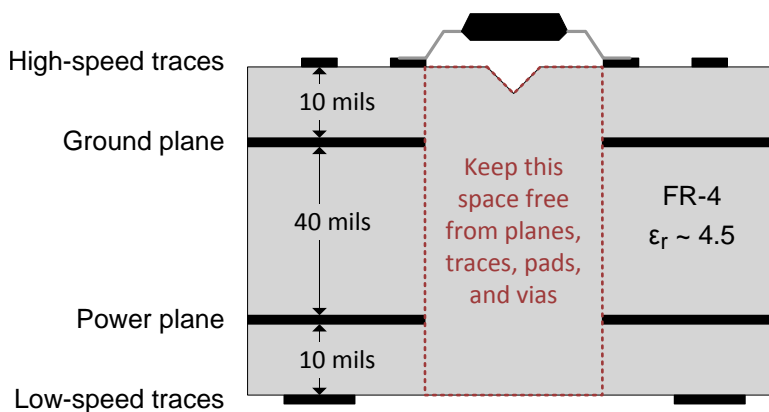

**Figure 20. Recommended Layer Stack**

## 12 Device and Documentation Support

### 12.1 Documentation Support

#### 12.1.1 Related Documentation

For related documentation see the following:

- *Digital Isolator Design Guide*, [SLLA284](#)
- *Isolation Glossary*, [SLLA353](#)
- *SN6501-Q1 Transformer Driver for Isolated Power Supplies*, [SLLSEF3](#)
- *SN65HVD231Q-Q1 3.3-V CAN Transceiver*, [SGLS398](#)
- *TMS320F28035 Piccolo™ Microcontrollers*, [SPRS584](#)
- *TPS76333-Q1 Low-Power 150-mA Low-Dropout Linear Regulators*, [SGLS247](#)

### 12.2 Related Links

The table below lists quick access links. Categories include technical documents, support and community resources, tools and software, and quick access to sample or buy.

Table 3. Related Links

PARTS	PRODUCT FOLDER	SAMPLE & BUY	TECHNICAL DOCUMENTS	TOOLS & SOFTWARE	SUPPORT & COMMUNITY
ISO7320-Q1	<a href="#">Click here</a>	<a href="#">Click here</a>	<a href="#">Click here</a>	<a href="#">Click here</a>	<a href="#">Click here</a>
ISO7321-Q1	<a href="#">Click here</a>	<a href="#">Click here</a>	<a href="#">Click here</a>	<a href="#">Click here</a>	<a href="#">Click here</a>

### 12.3 Community Resource

The following links connect to TI community resources. Linked contents are provided "AS IS" by the respective contributors. They do not constitute TI specifications and do not necessarily reflect TI's views; see TI's [Terms of Use](#).

**TI E2E™ Online Community** *TI's Engineer-to-Engineer (E2E) Community*. Created to foster collaboration among engineers. At [e2e.ti.com](#), you can ask questions, share knowledge, explore ideas and help solve problems with fellow engineers.

**Design Support** *TI's Design Support* Quickly find helpful E2E forums along with design support tools and contact information for technical support.

### 12.4 Trademarks

DeviceNet, Piccolo, E2E are trademarks of Texas Instruments. All other trademarks are the property of their respective owners.

### 12.5 Electrostatic Discharge Caution



These devices have limited built-in ESD protection. The leads should be shorted together or the device placed in conductive foam during storage or handling to prevent electrostatic damage to the MOS gates.

### 12.6 Glossary

[SLYZ022](#) — *TI Glossary*.

This glossary lists and explains terms, acronyms, and definitions.

## 13 Mechanical, Packaging, and Orderable Information

The following pages include mechanical packaging and orderable information. This information is the most current data available for the designated devices. This data is subject to change without notice and revision of this document. For browser-based versions of this data sheet, refer to the left-hand navigation.



## PACKAGE OUTLINE

**D0008B**

**SOIC - 1.75 mm max height**

SOIC

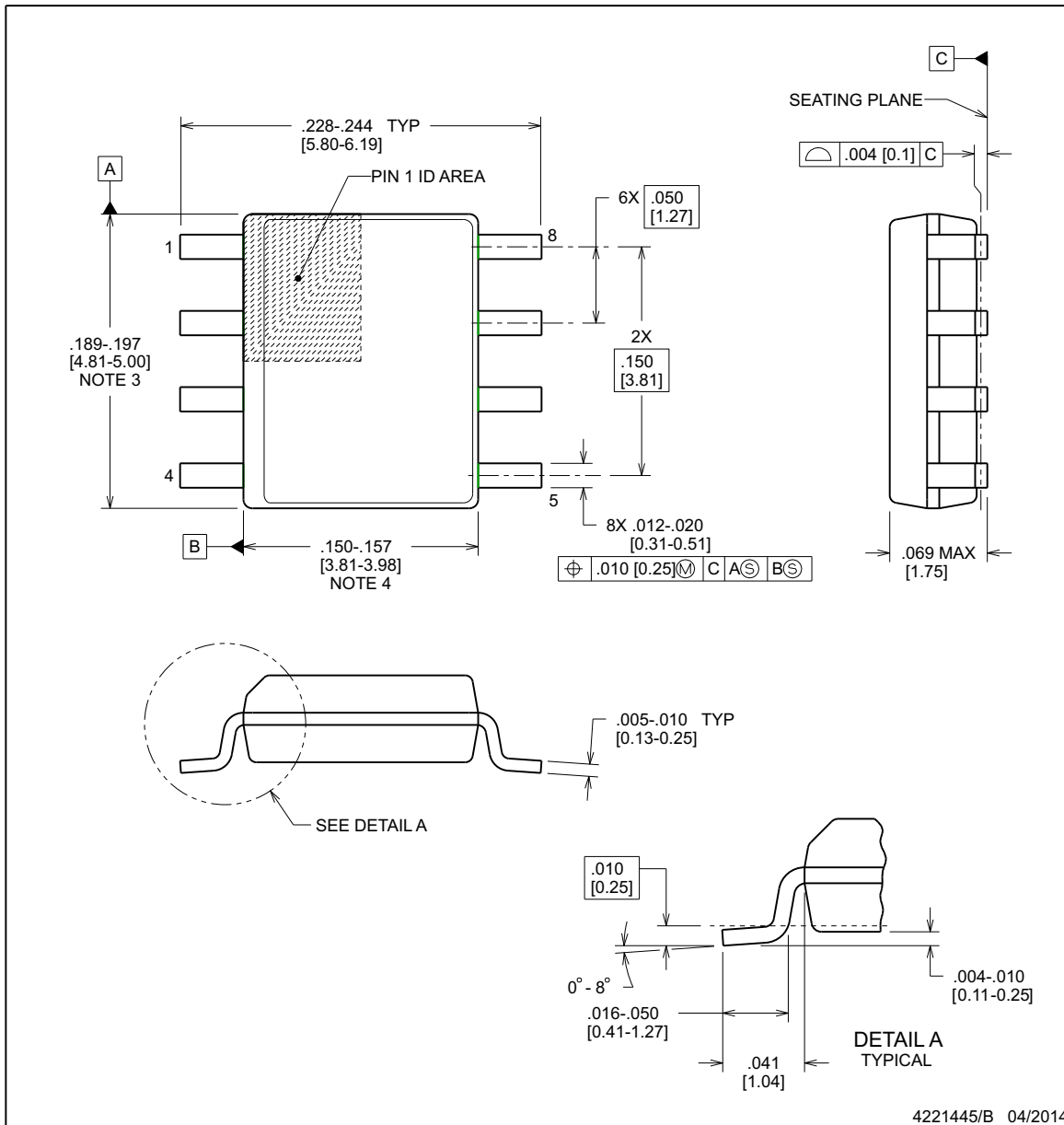

**NOTES:**

1. Linear dimensions are in inches [millimeters]. Dimensions in parenthesis are for reference only. Controlling dimensions are in inches. Dimensioning and tolerancing per ASME Y14.5M.
2. This drawing is subject to change without notice.
3. This dimension does not include mold flash, protrusions, or gate burrs. Mold flash, protrusions, or gate burrs shall not exceed  $.006$  [0.15], per side.
4. This dimension does not include interlead flash.
5. Reference JEDEC registration MS-012, variation AA.

## EXAMPLE BOARD LAYOUT

**D0008B**

**SOIC - 1.75 mm max height**

SOIC

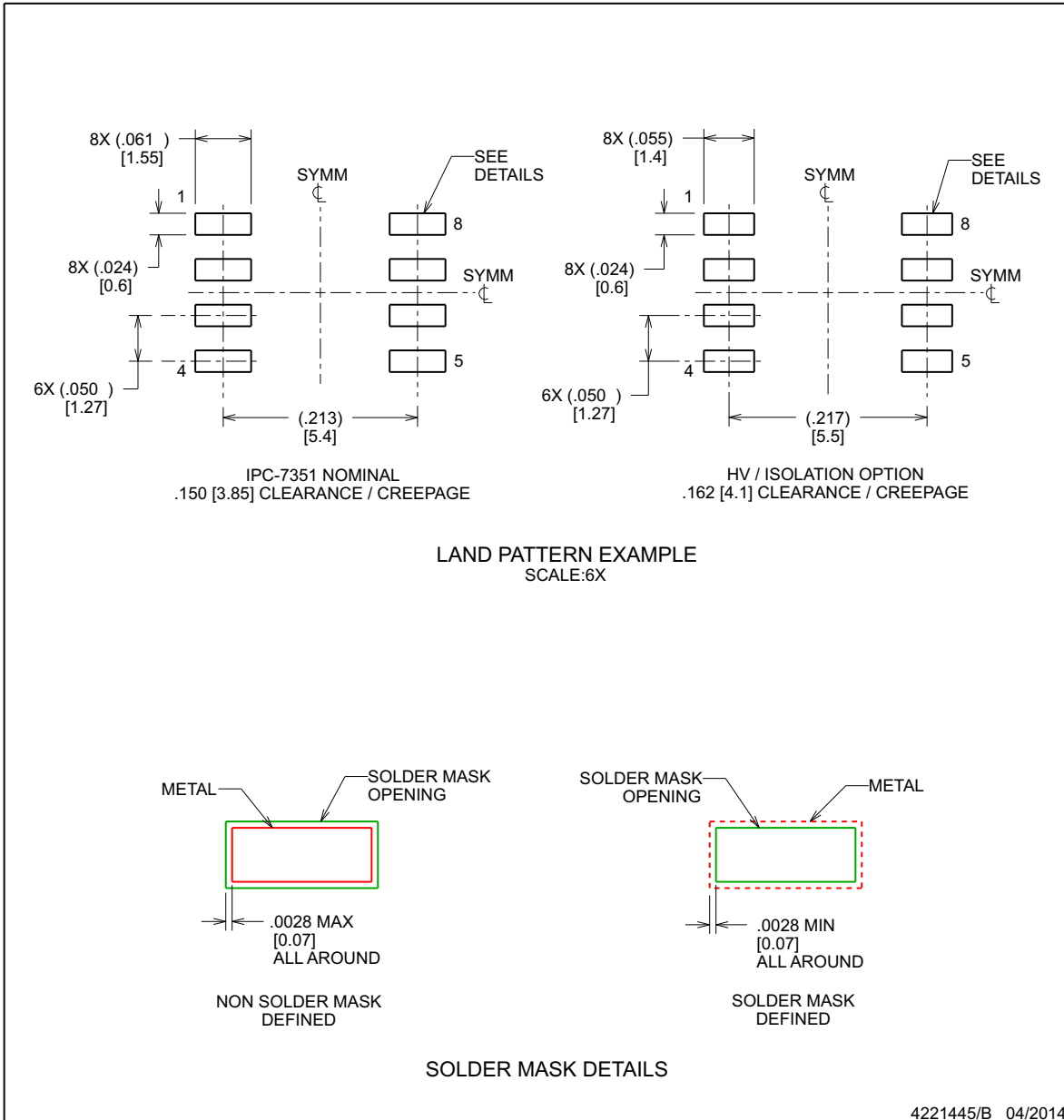

NOTES: (continued)

6. Publication IPC-7351 may have alternate designs.
7. Solder mask tolerances between and around signal pads can vary based on board fabrication site.

## EXAMPLE STENCIL DESIGN

**D0008B**

**SOIC - 1.75 mm max height**

SOIC

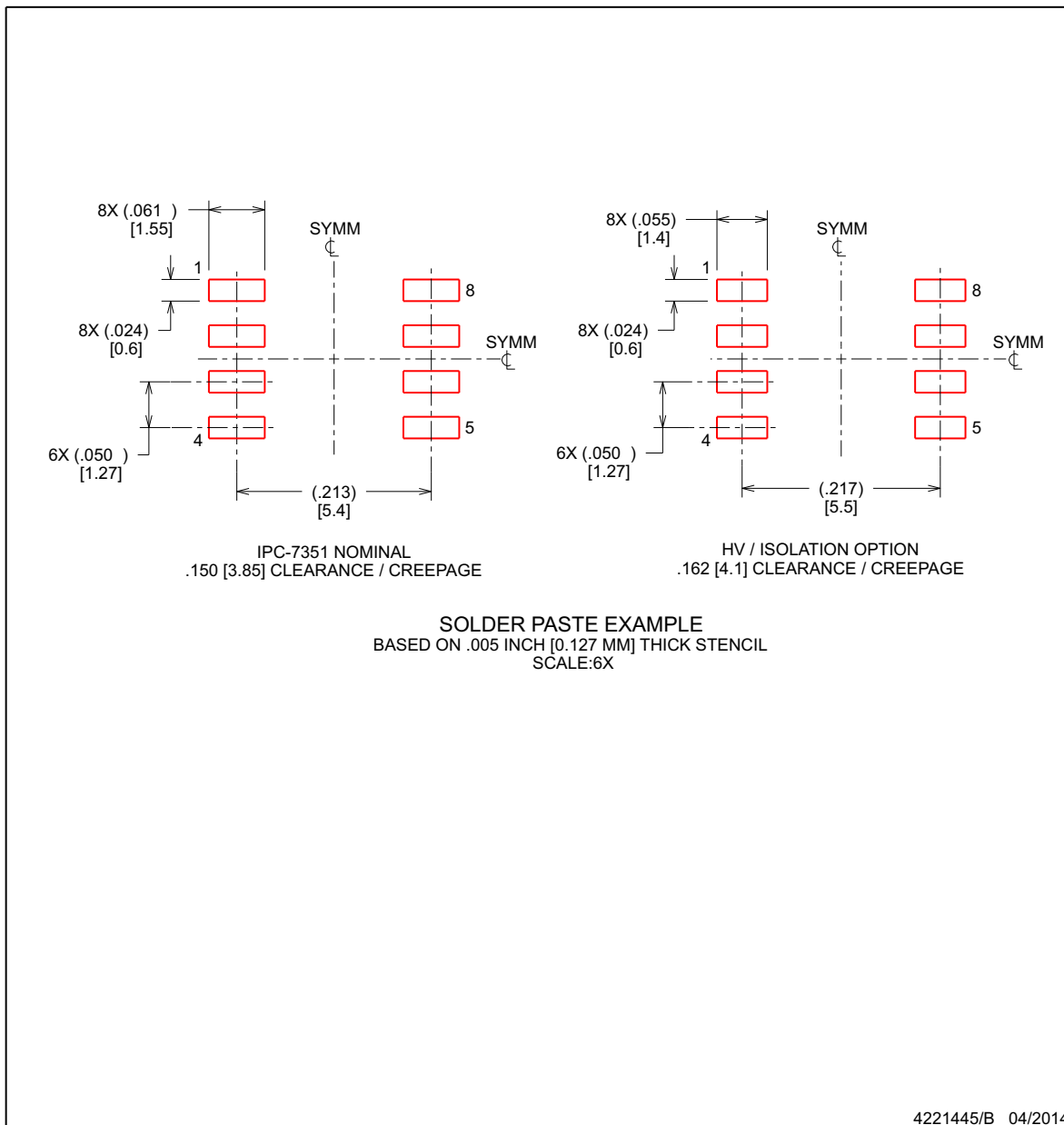

NOTES: (continued)

8. Laser cutting apertures with trapezoidal walls and rounded corners may offer better paste release. IPC-7525 may have alternate design recommendations.
9. Board assembly site may have different recommendations for stencil design.

**PACKAGING INFORMATION**

Orderable Device	Status (1)	Package Type	Package Drawing	Pins	Package Qty	Eco Plan (2)	Lead/Ball Finish (6)	MSL Peak Temp (3)	Op Temp (°C)	Device Marking (4/5)	Samples
ISO7320CQDQ1	ACTIVE	SOIC	D	8	75	Green (RoHS & no Sb/Br)	CU NIPDAU	Level-2-260C-1 YEAR	-40 to 125	7320Q	<a href="#">Samples</a>
ISO7320CQDRQ1	ACTIVE	SOIC	D	8	2500	Green (RoHS & no Sb/Br)	CU NIPDAU	Level-2-260C-1 YEAR	-40 to 125	7320Q	<a href="#">Samples</a>
ISO7320FCQDQ1	ACTIVE	SOIC	D	8	75	Green (RoHS & no Sb/Br)	CU NIPDAU	Level-2-260C-1 YEAR	-40 to 125	7320FQ	<a href="#">Samples</a>
ISO7320FCQDRQ1	ACTIVE	SOIC	D	8	2500	Green (RoHS & no Sb/Br)	CU NIPDAU	Level-2-260C-1 YEAR	-40 to 125	7320FQ	<a href="#">Samples</a>
ISO7321CQDQ1	ACTIVE	SOIC	D	8	75	Green (RoHS & no Sb/Br)	CU NIPDAU	Level-2-260C-1 YEAR	-40 to 125	7321Q	<a href="#">Samples</a>
ISO7321CQDRQ1	ACTIVE	SOIC	D	8	2500	Green (RoHS & no Sb/Br)	CU NIPDAU	Level-2-260C-1 YEAR	-40 to 125	7321Q	<a href="#">Samples</a>
ISO7321FCQDQ1	ACTIVE	SOIC	D	8	75	Green (RoHS & no Sb/Br)	CU NIPDAU	Level-2-260C-1 YEAR	-40 to 125	7321FQ	<a href="#">Samples</a>
ISO7321FCQDRQ1	ACTIVE	SOIC	D	8	2500	Green (RoHS & no Sb/Br)	CU NIPDAU	Level-2-260C-1 YEAR	-40 to 125	7321FQ	<a href="#">Samples</a>

(1) The marketing status values are defined as follows:

**ACTIVE:** Product device recommended for new designs.

**LIFEBUY:** TI has announced that the device will be discontinued, and a lifetime-buy period is in effect.

**NRND:** Not recommended for new designs. Device is in production to support existing customers, but TI does not recommend using this part in a new design.

**PREVIEW:** Device has been announced but is not in production. Samples may or may not be available.

**OBSOLETE:** TI has discontinued the production of the device.

(2) Eco Plan - The planned eco-friendly classification: Pb-Free (RoHS), Pb-Free (RoHS Exempt), or Green (RoHS & no Sb/Br) - please check <http://www.ti.com/productcontent> for the latest availability information and additional product content details.

**TBD:** The Pb-Free/Green conversion plan has not been defined.

**Pb-Free (RoHS):** TI's terms "Lead-Free" or "Pb-Free" mean semiconductor products that are compatible with the current RoHS requirements for all 6 substances, including the requirement that lead not exceed 0.1% by weight in homogeneous materials. Where designed to be soldered at high temperatures, TI Pb-Free products are suitable for use in specified lead-free processes.

**Pb-Free (RoHS Exempt):** This component has a RoHS exemption for either 1) lead-based flip-chip solder bumps used between the die and package, or 2) lead-based die adhesive used between the die and leadframe. The component is otherwise considered Pb-Free (RoHS compatible) as defined above.

**Green (RoHS & no Sb/Br):** TI defines "Green" to mean Pb-Free (RoHS compatible), and free of Bromine (Br) and Antimony (Sb) based flame retardants (Br or Sb do not exceed 0.1% by weight in homogeneous material)

(3) MSL, Peak Temp. - The Moisture Sensitivity Level rating according to the JEDEC industry standard classifications, and peak solder temperature.

(4) There may be additional marking, which relates to the logo, the lot trace code information, or the environmental category on the device.

(5) Multiple Device Markings will be inside parentheses. Only one Device Marking contained in parentheses and separated by a "~" will appear on a device. If a line is indented then it is a continuation of the previous line and the two combined represent the entire Device Marking for that device.

(6) Lead/Ball Finish - Orderable Devices may have multiple material finish options. Finish options are separated by a vertical ruled line. Lead/Ball Finish values may wrap to two lines if the finish value exceeds the maximum column width.

**Important Information and Disclaimer:**The information provided on this page represents TI's knowledge and belief as of the date that it is provided. TI bases its knowledge and belief on information provided by third parties, and makes no representation or warranty as to the accuracy of such information. Efforts are underway to better integrate information from third parties. TI has taken and continues to take reasonable steps to provide representative and accurate information but may not have conducted destructive testing or chemical analysis on incoming materials and chemicals. TI and TI suppliers consider certain information to be proprietary, and thus CAS numbers and other limited information may not be available for release.

In no event shall TI's liability arising out of such information exceed the total purchase price of the TI part(s) at issue in this document sold by TI to Customer on an annual basis.

**TAPE AND REEL INFORMATION**

**QUADRANT ASSIGNMENTS FOR PIN 1 ORIENTATION IN TAPE**

\*All dimensions are nominal

Device	Package Type	Package Drawing	Pins	SPQ	Reel Diameter (mm)	Reel Width W1 (mm)	A0 (mm)	B0 (mm)	K0 (mm)	P1 (mm)	W (mm)	Pin1 Quadrant
ISO7320CQDRQ1	SOIC	D	8	2500	330.0	12.4	6.4	5.2	2.1	8.0	12.0	Q1
ISO7320FCQDRQ1	SOIC	D	8	2500	330.0	12.4	6.4	5.2	2.1	8.0	12.0	Q1
ISO7321CQDRQ1	SOIC	D	8	2500	330.0	12.4	6.4	5.2	2.1	8.0	12.0	Q1
ISO7321FCQDRQ1	SOIC	D	8	2500	330.0	12.4	6.4	5.2	2.1	8.0	12.0	Q1

**TAPE AND REEL BOX DIMENSIONS**

\*All dimensions are nominal

Device	Package Type	Package Drawing	Pins	SPQ	Length (mm)	Width (mm)	Height (mm)
ISO7320CQDRQ1	SOIC	D	8	2500	367.0	367.0	35.0
ISO7320FCQDRQ1	SOIC	D	8	2500	367.0	367.0	35.0
ISO7321CQDRQ1	SOIC	D	8	2500	367.0	367.0	35.0
ISO7321FCQDRQ1	SOIC	D	8	2500	367.0	367.0	35.0

## IMPORTANT NOTICE

Texas Instruments Incorporated and its subsidiaries (TI) reserve the right to make corrections, enhancements, improvements and other changes to its semiconductor products and services per JESD46, latest issue, and to discontinue any product or service per JESD48, latest issue. Buyers should obtain the latest relevant information before placing orders and should verify that such information is current and complete. All semiconductor products (also referred to herein as "components") are sold subject to TI's terms and conditions of sale supplied at the time of order acknowledgment.

TI warrants performance of its components to the specifications applicable at the time of sale, in accordance with the warranty in TI's terms and conditions of sale of semiconductor products. Testing and other quality control techniques are used to the extent TI deems necessary to support this warranty. Except where mandated by applicable law, testing of all parameters of each component is not necessarily performed.

TI assumes no liability for applications assistance or the design of Buyers' products. Buyers are responsible for their products and applications using TI components. To minimize the risks associated with Buyers' products and applications, Buyers should provide adequate design and operating safeguards.

TI does not warrant or represent that any license, either express or implied, is granted under any patent right, copyright, mask work right, or other intellectual property right relating to any combination, machine, or process in which TI components or services are used. Information published by TI regarding third-party products or services does not constitute a license to use such products or services or a warranty or endorsement thereof. Use of such information may require a license from a third party under the patents or other intellectual property of the third party, or a license from TI under the patents or other intellectual property of TI.

Reproduction of significant portions of TI information in TI data books or data sheets is permissible only if reproduction is without alteration and is accompanied by all associated warranties, conditions, limitations, and notices. TI is not responsible or liable for such altered documentation. Information of third parties may be subject to additional restrictions.

Resale of TI components or services with statements different from or beyond the parameters stated by TI for that component or service voids all express and any implied warranties for the associated TI component or service and is an unfair and deceptive business practice. TI is not responsible or liable for any such statements.

Buyer acknowledges and agrees that it is solely responsible for compliance with all legal, regulatory and safety-related requirements concerning its products, and any use of TI components in its applications, notwithstanding any applications-related information or support that may be provided by TI. Buyer represents and agrees that it has all the necessary expertise to create and implement safeguards which anticipate dangerous consequences of failures, monitor failures and their consequences, lessen the likelihood of failures that might cause harm and take appropriate remedial actions. Buyer will fully indemnify TI and its representatives against any damages arising out of the use of any TI components in safety-critical applications.

In some cases, TI components may be promoted specifically to facilitate safety-related applications. With such components, TI's goal is to help enable customers to design and create their own end-product solutions that meet applicable functional safety standards and requirements. Nonetheless, such components are subject to these terms.

No TI components are authorized for use in FDA Class III (or similar life-critical medical equipment) unless authorized officers of the parties have executed a special agreement specifically governing such use.

Only those TI components which TI has specifically designated as military grade or "enhanced plastic" are designed and intended for use in military/aerospace applications or environments. Buyer acknowledges and agrees that any military or aerospace use of TI components which have **not** been so designated is solely at the Buyer's risk, and that Buyer is solely responsible for compliance with all legal and regulatory requirements in connection with such use.

TI has specifically designated certain components as meeting ISO/TS16949 requirements, mainly for automotive use. In any case of use of non-designated products, TI will not be responsible for any failure to meet ISO/TS16949.

### Products

Audio	<a href="http://www.ti.com/audio">www.ti.com/audio</a>
Amplifiers	<a href="http://amplifier.ti.com">amplifier.ti.com</a>
Data Converters	<a href="http://dataconverter.ti.com">dataconverter.ti.com</a>
DLP® Products	<a href="http://www.dlp.com">www.dlp.com</a>
DSP	<a href="http://dsp.ti.com">dsp.ti.com</a>
Clocks and Timers	<a href="http://www.ti.com/clocks">www.ti.com/clocks</a>
Interface	<a href="http://interface.ti.com">interface.ti.com</a>
Logic	<a href="http://logic.ti.com">logic.ti.com</a>
Power Mgmt	<a href="http://power.ti.com">power.ti.com</a>
Microcontrollers	<a href="http://microcontroller.ti.com">microcontroller.ti.com</a>
RFID	<a href="http://www.ti-rfid.com">www.ti-rfid.com</a>
OMAP Applications Processors	<a href="http://www.ti.com/omap">www.ti.com/omap</a>
Wireless Connectivity	<a href="http://www.ti.com/wirelessconnectivity">www.ti.com/wirelessconnectivity</a>

### Applications

Automotive and Transportation	<a href="http://www.ti.com/automotive">www.ti.com/automotive</a>
Communications and Telecom	<a href="http://www.ti.com/communications">www.ti.com/communications</a>
Computers and Peripherals	<a href="http://www.ti.com/computers">www.ti.com/computers</a>
Consumer Electronics	<a href="http://www.ti.com/consumer-apps">www.ti.com/consumer-apps</a>
Energy and Lighting	<a href="http://www.ti.com/energy">www.ti.com/energy</a>
Industrial	<a href="http://www.ti.com/industrial">www.ti.com/industrial</a>
Medical	<a href="http://www.ti.com/medical">www.ti.com/medical</a>
Security	<a href="http://www.ti.com/security">www.ti.com/security</a>
Space, Avionics and Defense	<a href="http://www.ti.com/space-avionics-defense">www.ti.com/space-avionics-defense</a>
Video and Imaging	<a href="http://www.ti.com/video">www.ti.com/video</a>

### TI E2E Community

[e2e.ti.com](http://e2e.ti.com)